

Steel and steel products — Location and preparation of samples and test pieces for mechanical testing

The European Standard EN ISO 377 : 1997 has the status of a
British Standard

ICS 77.040.10

NO COPYING WITHOUT BSI PERMISSION EXCEPT AS PERMITTED BY COPYRIGHT LAW



* S *

National foreword

This British Standard is the English language version of EN ISO 377 : 1997. It is identical with ISO 377 : 1997.

The UK participation in its preparation was entrusted to Technical Committee ISE/5, Steering committee (ISO) on sampling and delivery conditions for steel, which has the responsibility to:

- aid enquirers to understand the text;
- present to the responsible international/European committee any enquiries on the interpretation, or proposals for change, and keep the UK interests informed;
- monitor related international and European developments and promulgate them in the UK.

A list of organizations represented on this committee can be obtained on request to its secretary.

Cross-references

Attention is drawn to the fact that CEN and CENELEC Standards normally include an annex which lists normative references to international publications with their corresponding European publications. The British Standards which implement these international or European publications may be found in the BSI Standards Catalogue under the section entitled 'International Standards Correspondence Index', or using the 'Find' facility of the BSI Standards Electronic Catalogue.

Compliance with a British Standard does not of itself confer immunity from legal obligations.

Summary of pages

This document comprises a front cover, an inside front cover, the EN ISO title page, the EN ISO foreword page, the ISO title page, page ii, pages 1 to 17, the annex ZA page, an inside back cover and a back cover.

This British Standard, having been prepared under the direction of the Engineering Sector Board, was published under the authority of the Standards Board and comes into effect on 15 September 1997

© BSI 1997

ISBN 0 580 27871 9

Amendments issued since publication

Amd. No.	Date	Text affected

EUROPEAN STANDARD

EN ISO 377

NORME EUROPÉENNE

EUROPÄISCHE NORM

July 1997

ICS 77.040.10; 77.140.01

Descriptors: See ISO document

English version

Steel and steel products - Location and preparation of samples and test pieces for mechanical testing (ISO 377:1997)

Acier et produits en acier - Position et préparation des échantillons et éprouvettes pour essais mécaniques (ISO 377:1997)

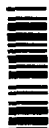

*
S
*

This European Standard was approved by CEN on 1997-06-12. CEN members are bound to comply with the CEN/CENELEC Internal Regulations which stipulate the conditions for giving this European Standard the status of a national standard without any alteration.

Up-to-date lists and bibliographical references concerning such national standards may be obtained on application to the Central Secretariat or to any CEN member.

The European Standards exist in three official versions (English, French, German). A version in any other language made by translation under the responsibility of a CEN member into its own language and notified to the Central Secretariat has the same status as the official versions.

CEN members are the national standards bodies of Austria, Belgium, Czech Republic, Denmark, Finland, France, Germany, Greece, Iceland, Ireland, Italy, Luxembourg, Netherlands, Norway, Portugal, Spain, Sweden, Switzerland and United Kingdom.

CEN

European Committee for Standardization
Comité Européen de Normalisation
Europäisches Komitee für Normung

Central Secretariat: rue de Stassart, 36 B-1050 Brussels

© 1997 CEN - All rights of exploitation in any form and by any means reserved worldwide for CEN national Members.

Ref. No. EN ISO 377:1997 E

EN ISO 377 : 1997**Foreword**

The text of the International Standard ISO 377:1997 has been prepared by Technical Committee ISO/TC 17 "Steel" in collaboration with Technical Committee ECISS/TC 9 "Technical conditions of delivery and quality control", the secretariat of which is held by IBN/BIN.

This European Standard shall be given the status of a national standard, either by publication of an identical text or by endorsement, at the latest by January 1998, and conflicting national standards shall be withdrawn at the latest by January 1998.

According to the CEN/CENELEC Internal Regulations, the national standards organizations of the following countries are bound to implement this European Standard: Austria, Belgium, Czech Republic, Denmark, Finland, France, Germany, Greece, Iceland, Ireland, Italy, Luxembourg, Netherlands, Norway, Portugal, Spain, Sweden, Switzerland and the United Kingdom.

Endorsement notice

The text of the International Standard ISO 377:1997 was approved by CEN as a European Standard without any modification.

NOTE: Normative references to International Standards are listed in annex ZA (normative).

**INTERNATIONAL
STANDARD**

**ISO
377**

Second edition
1997-07-15

**Steel and steel products — Location
and preparation of samples and test
pieces for mechanical testing**

*Acier et produits en acier — Position et préparation des échantillons
et éprouvettes pour essais mécaniques*



* S *



Reference number
ISO 377:1997(E)

EN ISO 377 : 1997**Foreword**

ISO (the International Organization for Standardization) is a worldwide federation of national standards bodies (ISO member bodies). The work of preparing International Standards is normally carried out through ISO technical committees. Each member body interested in a subject for which a technical committee has been established has the right to be represented on that committee. International organizations, governmental and non-governmental, in liaison with ISO, also take part in the work. ISO collaborates closely with the International Electrotechnical Commission (IEC) on all matters of electrotechnical standardization.

Draft International Standards adopted by the technical committees are circulated to the member bodies for voting. Publication as an International Standard requires approval by at least 75 % of the member bodies casting a vote.

International Standard ISO 377 was prepared by Technical Committee ISO/TC 17, *Steel*, Subcommittee SC 20, *General technical delivery conditions, sampling and mechanical testing methods*.

This second edition of ISO 377 cancels and replaces ISO 377-1:1989, which has been technically revised.

Annex A forms an integral part of this International Standard.

Descriptors: steels, iron and steel products, sampling, sampling location, samples, specimen preparation, mechanical tests.

Steel and steel products — Location and preparation of samples and test pieces for mechanical testing

1 Scope

This International Standard specifies requirements for the identification, location and preparation of samples and test pieces intended for mechanical tests on steel sections, bars, rod, flat products and tubular products as defined in ISO 6929. If agreed in the order this standard may also apply to other metallic products. It does not apply to non-destructive tests.

These samples and test pieces are for use in tests which are carried out in conformity with the methods specified in the product or material standard or, in the absence of this, in the test standard.

Where the requirements of the order or product standard differ from those given in this International Standard, then the requirements of the order or product standard apply.

2 Normative references

The following standards contain provisions which, through reference in this text, constitute provisions of this International Standard. At the time of publication, the editions indicated were valid. All standards are subject to revision, and parties to agreements based on this International Standard are encouraged to investigate the possibility of applying the most recent editions of the standards indicated below. Members of IEC and ISO maintain registers of currently valid International Standards.

ISO 3785:—1), *Metallic materials — Designation of test piece axes.*

ISO 6929:1987, *Steel products — Definitions and classification.*

3 Definitions

For the purposes of this International Standard, the definitions given in ISO 6929 and the following apply.

3.1 test unit: Number of pieces or the tonnage of products to be accepted or rejected together, on the basis of the tests to be carried out on sample products in accordance with the requirements of the product standard or order. (See figure 1.)

3.2 sample product: Item (e.g. bar, sheet, coil) selected for inspection and/or testing. (See figure 1.)

1) To be published. (Revision of ISO 3785:1976)

EN ISO 377 : 1997

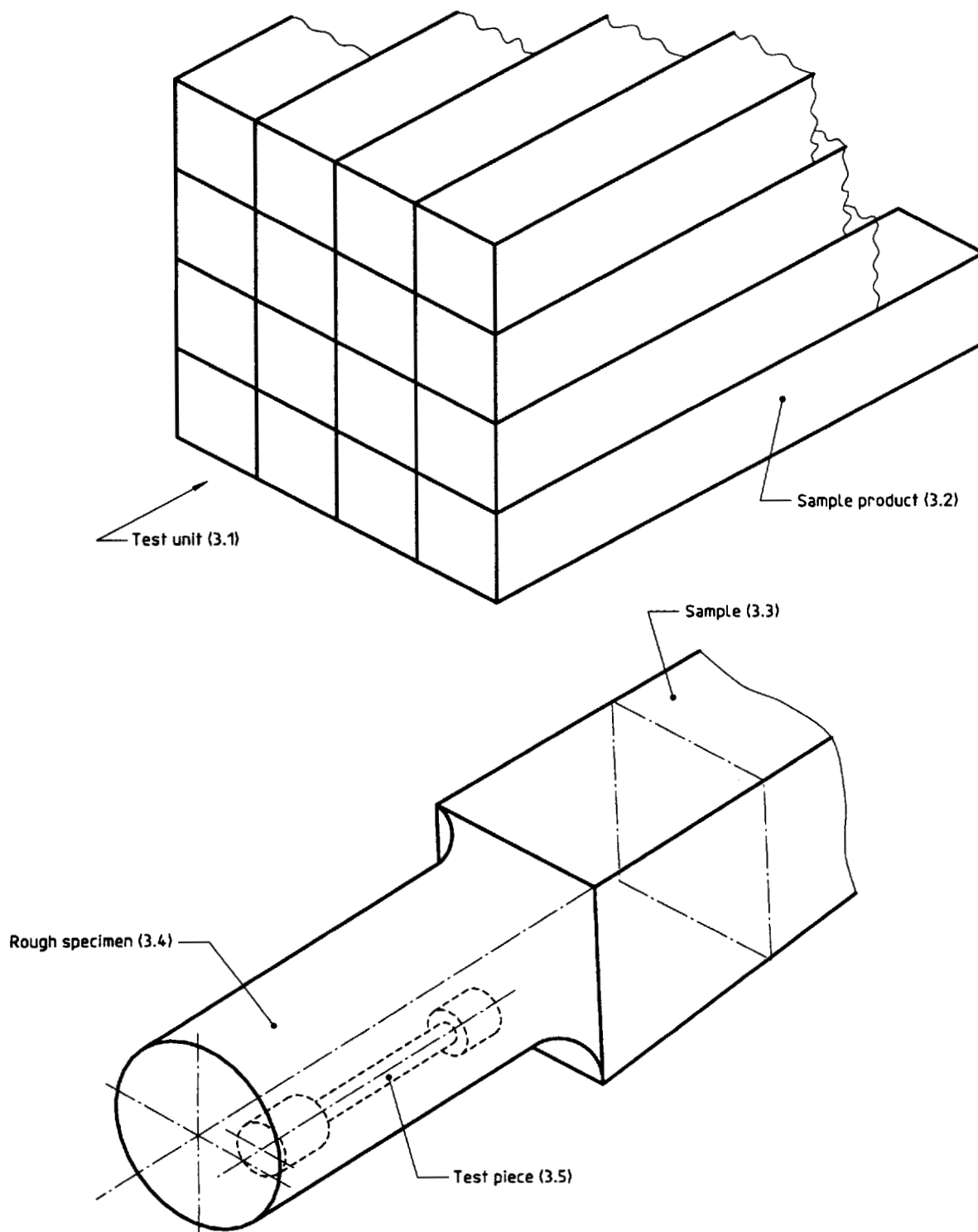

Figure 1 — Examples of terms defined in clause 3

3.3 sample: Sufficient quantity of material taken from the sample product for the purpose of producing one or more test pieces. (See figure 1.)

NOTE — In certain cases, the sample may be the sample product.

3.4 rough specimen: Part of a sample having undergone mechanical treatment, for the purpose of producing a test piece. (See figure 1.)

3.5 test piece: Part of a sample or rough specimen, with specified dimensions, machined or unmachined, brought to a required condition for submission to a given test. (See figure 1.)

NOTE — In certain cases, the test piece may be the sample or the rough specimen.

3.6 reference condition: Condition of a sample, rough specimen or test piece having undergone a heat treatment to represent the intended final condition of the product.

NOTE — In such cases the sample, rough specimen or test piece is called the reference sample, reference rough specimen or reference test piece.

4 General requirements

4.1 Representative testing

Sample, rough specimens and test pieces selected in accordance with annex A, shall be considered to be representative of the product.

NOTE — As a result of their production sequence i.e. melting, casting hot and/or cold forming, heat treatment etc., steel products are not homogeneous. The mechanical properties of samples taken from other locations may be different.

4.2 Identification of sample products, samples, rough specimens and test pieces

Sample products, samples, rough specimens and test pieces shall be marked to ensure traceability to the original product and their location and orientation in that product. For this purpose, if, during the preparation of the sample, rough specimen and/or test pieces, removal of the marks cannot be avoided, transfer of these marks shall be carried out before the existing marks are removed or in the case of automatic preparation equipment before the test piece is removed from the equipment. In the case of specific inspection and testing and where requested by the purchaser the transfer of the marks shall be carried out in the presence of the purchaser's representative.

In the case of fully automatic in line preparation and testing systems, marking of samples, rough specimens and test pieces is not necessary if an adequate control system exists, which clearly defines the procedures to be followed in the event of system failure.

5 Preparation of samples and selection of test pieces

5.1 Selection and dimensions of samples and location of test pieces

The sample shall be selected so that the test piece can be located as indicated in annex A. The sample shall have sufficient dimensions to allow sufficient test pieces required for carrying out specified tests, and for any retests which may be necessary.

5.2 Direction of axis of test pieces

The direction of the test piece axis relative to the principle direction of working shall be as specified in the appropriate product standard or order. The designation of the test piece axis shall be in accordance with ISO 3785.

EN ISO 377 : 1997**5.3 Condition and separation of samples****5.3.1 General**

The material or product standard shall specify whether the test is intended to determine the properties,

- a) in the as-delivered condition (see 5.3.2) or
- b) in the reference condition (see 5.3.3).

5.3.2 Testing in the as-delivered condition

A sample intended for testing in the as-delivered condition shall be separated from the product either

- a) after the forming and heat treatment processes have been completed or
- b) before the heat treatment process, in which case the heat treatment of the separated sample shall be carried out under the same conditions as that of the product.

Separation of the sample shall be carried out in such a manner so as not to change the characteristics of that part of the sample used to provide the test pieces.

Where flattening or straightening of the sample is unavoidable in the preparation of the test piece, it shall be carried out cold unless otherwise specified in the product standard.

5.3.3 Testing in the reference condition**5.3.3.1 Sample**

A sample intended for testing in the reference condition shall be separated from the product at the stage of manufacture specified in the product standard or order.

Separation of the sample shall be carried out in such a manner so as not to change the characteristics of that part of the sample used to provide the test pieces after heat treatment.

NOTE — When flattening or straightening is necessary it may be carried out either hot or cold before any heat treatment. When carried out hot it should be at a temperature below the final heat treatment temperature.

5.3.3.2 Rough specimen

A rough specimen intended for testing in the reference condition shall be prepared as follows.

- a) **Mechanical treatment prior to heat treatment:** when the sample is to be made smaller for the process of heat treatment, the product standard shall specify the dimensions to which the rough specimen shall be reduced and the reduction process e.g. forging, rolling, machining.
- b) **Heat treatment:** the heat treatment of the rough specimen shall take place in an environment where the uniformity of the temperature is adequately assured and the temperature is measured by means of a calibrated instrument. The heat treatment shall be in accordance with the requirements of the product standard or of the order.

6 Preparation of test pieces

6.1 Cutting and machining

Cutting and machining of samples and rough specimens for the preparation of test pieces shall be carried out taking such precautions as necessary to avoid superficial work hardening and heating of the material likely to change the mechanical characteristics. After machining, any marks left by the tool which might interfere with the results of the test shall be removed, either by grinding (with ample coolant supply) or by polishing, provided that the chosen method of finishing maintains the dimensions and shape of the test piece within the tolerances specified in the standard for appropriate test.

The tolerances on the dimensions of the test pieces shall be those specified in the appropriate test methods.

6.2 Reference heat treatment

When the required reference heat treatment is to be carried out on the test piece the provisions for heat treatment shall be the same as for the rough specimen [see 5.3.3.2 b)].



* S *

Annex A

(normative)

Location of samples and test pieces

A.1 General

This annex applies to the location of test pieces for the following product forms

- sections;
- bars and rod;
- flat products;
- tubular products.

The location of test pieces for tensile and impact tests are indicated in figures A.1 to A.15. For bend tests the width position is as for the tensile test pieces.

Where more than one test piece is required they may be placed adjacent to each other in the location specified.

A.2 Sections

A.2.1 Location of test pieces across the width of section

The location of test pieces shall be in accordance with figure A.1.

NOTES

- 1 For sections with tapered flanges; if agreed at the time of enquiry and ordering the sample may be taken from the web [see figure A.1 b) and d)] or the sample from the tapered flange may be machined.
- 2 For unequal leg angles, samples may be taken from either leg.

A.2.2 Location of test pieces in thickness of section

A.2.2.1 Tensile test pieces

The location of tensile test pieces shall be in accordance with figure A.2. Full thickness test pieces [see figure A.2 a)] shall be used whenever machining and test equipment allows.

A.2.2.2 Impact test pieces

The location of impact test pieces shall be in accordance with figure A.3.

A.3 Round bars and rod

A.3.1 Tensile test pieces

The location of tensile test pieces shall be selected in accordance with figure A.4. Full section test pieces [see figure A.4 a)] shall be used whenever machining and test equipment allows.

A.3.2 Impact test pieces

The location of impact test pieces shall be selected in accordance with figure A.5.

A.4 Hexagonal bar

A.4.1 Tensile test pieces

The location of tensile test pieces shall be selected in accordance with figure A.6.

Full section test pieces [see figure A.6 a)] shall be used wherever machining and test equipment allows.

A.4.2 Impact test pieces

The location of impact test pieces shall be selected in accordance with figure A.7.

A.5 Rectangular bar

A.5.1 Tensile test pieces

The location of tensile test pieces shall be in accordance with figure A.8.

Full section or rectangular test pieces [see figures A.8 a), b) or c)] shall be used whenever machining and test equipment allow.

A.5.2 Impact test pieces

The location of impact test pieces shall be in accordance with figure A.9.

A.6 Flat products

A.6.1 Tensile test pieces

The location of tensile test pieces shall be in accordance with figure A.10.

Full section test pieces [see figure A.10 a)] shall be used whenever machining and test equipment allow.

Where transverse tensile test pieces are specified and the width of flat product is not sufficient to take the test piece from the $\frac{w}{4}$ location, then the centre of the test piece shall be as near to $\frac{w}{4}$ as possible.

A.6.2 Impact test pieces

The location of impact test pieces shall be in accordance with figure A.11. For products of thickness ≥ 40 mm the location [figure A.11 a), b) or c)] shall be specified in the product standard or in the order.



EN ISO 377 : 1997**A.7 Tubular products****A.7.1 Tubes and circular hollow sections****A.7.1.1 Tensile test pieces**

The location of tensile test pieces shall be selected in accordance with figure A.12. Full section test pieces [figure A.12 a)] shall be used whenever machining and test equipment allow.

For welded tubes, when testing the weld using strip test pieces, the weld shall be at the centre of the test piece.

NOTES

1 The full section test piece as shown in figure A.12 a) is also applicable for a tube:

- flattening test;
- drift expanding test;
- flanging test;
- ring expanding test;
- ring tensile test;
- bend test in full section;

2 Test pieces shown in figure A.12 b) are used for strip bend test.

If not specified in the product standard or in the order the sampling position is at the discretion of the manufacturer.

A.7.1.2 Impact test pieces

The location of impact test pieces shall be in accordance with figure A.13. The locations apply to both seamless and welded tubes.

If not specified in the product standard or in the order the sampling position is at the discretion of the manufacturer.

The orientation of test pieces is determined by the dimensions of the tube. Where a test piece is required in the transverse position the widest possible size between 10 mm and 5 mm shall be produced.

The minimum (nominal) diameter D_{mm} of the tube necessary to obtain such a test piece is given by:

$$D_{\text{min}} = (T - 5) + \frac{756,25}{T - 5}$$

where T is the wall thickness.

Where the smallest permitted transverse test piece is not obtainable, the widest possible longitudinal size between 10 mm and 5 mm shall be used.

A.7.2 Rectangular hollow sections**A.7.2.1 Tensile test pieces**

The location of tensile test pieces shall be in accordance with figure A.14. Full section test pieces [see figure A.14 a)] shall be used whenever machining and test equipment allow.

A.7.2.2 Impact test pieces

The location of impact test pieces shall be in accordance with figure A.15.

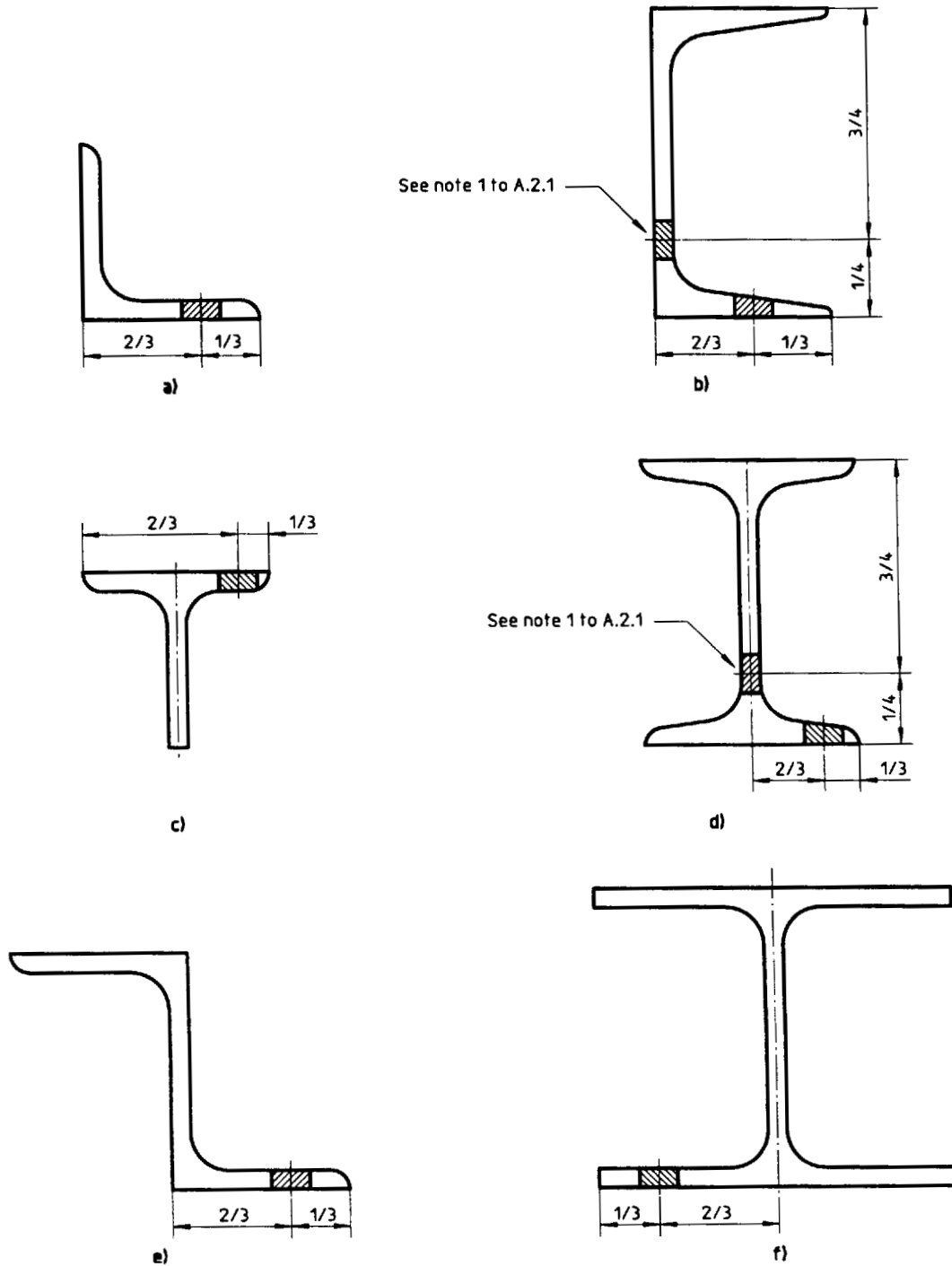

Figure A.1 — Sections — Location of test pieces for tensile and impact testing in width of flange (see A.2.1)

S

Dimensions in millimetres

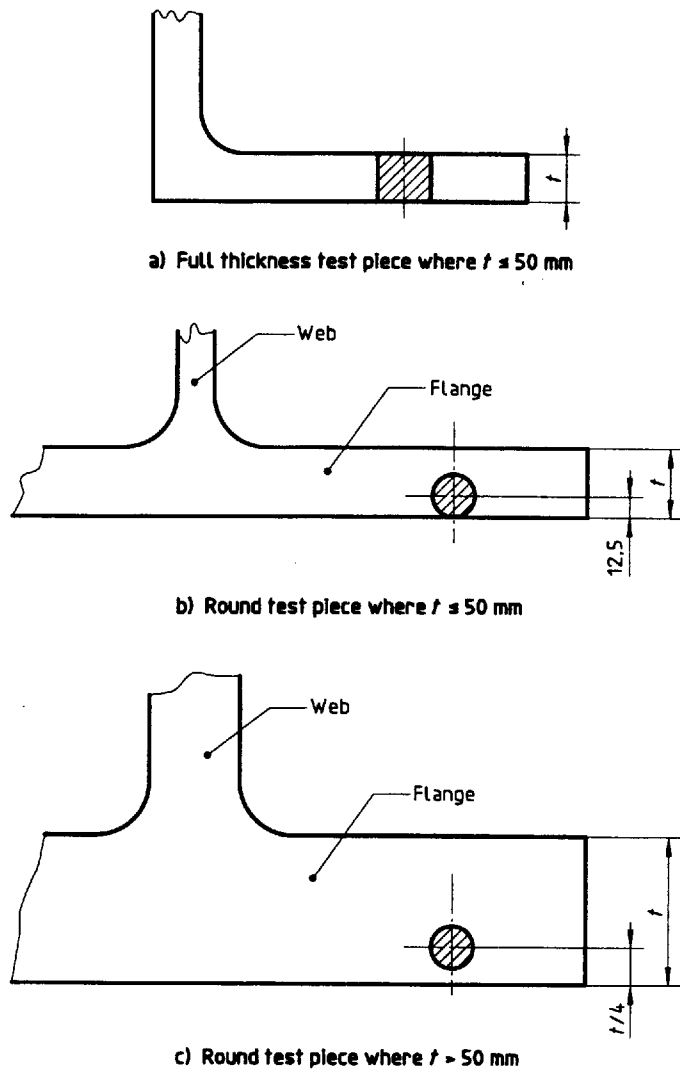

Figure A.2 — Sections — Location of test pieces for tensile testing in thickness of flange (see A.2.2.1)

Dimensions in millimetres

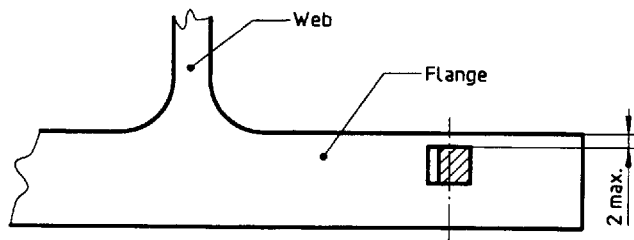

Figure A.3 — Sections — Location of test pieces for impact testing in thickness of flange (see A.2.2.2)

Dimensions in millimetres



Figure A.4 — Round bar and rod — Location of test pieces for tensile testing (see A.3.1)

Dimensions in millimetres

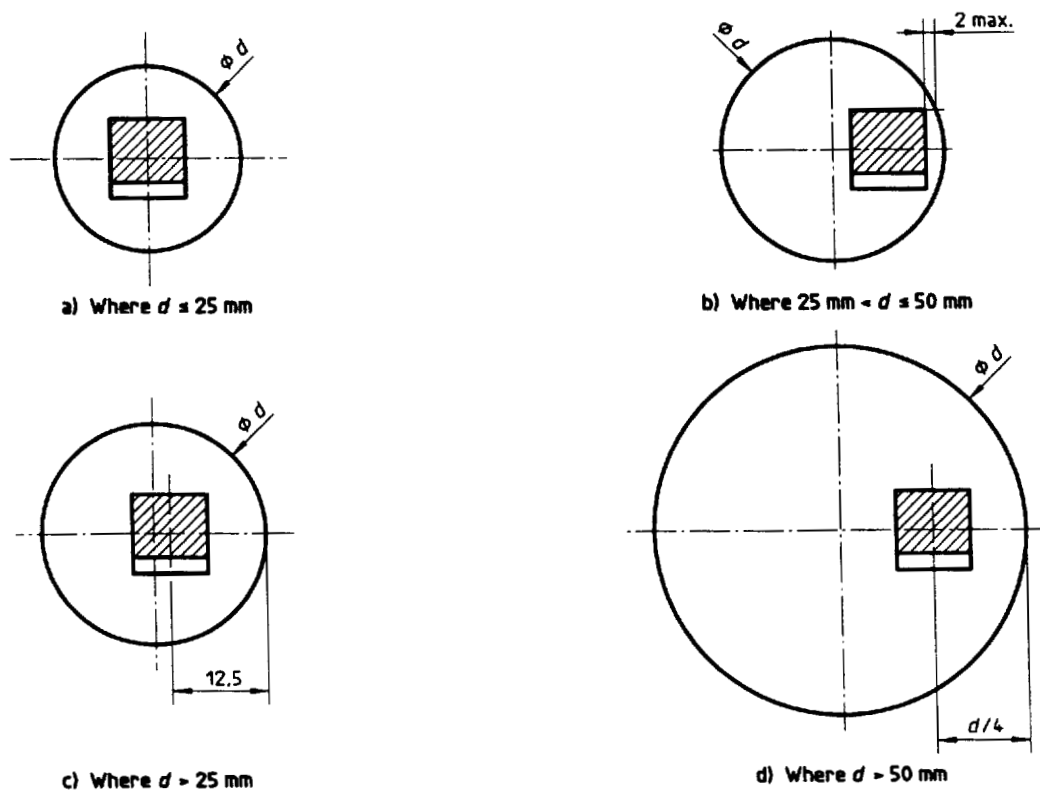
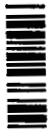

Figure A.5 -- Round bar and rod — Location of test pieces for impact testing (see A.3.2)



S

EN ISO 377 : 1997

Dimensions in millimetres

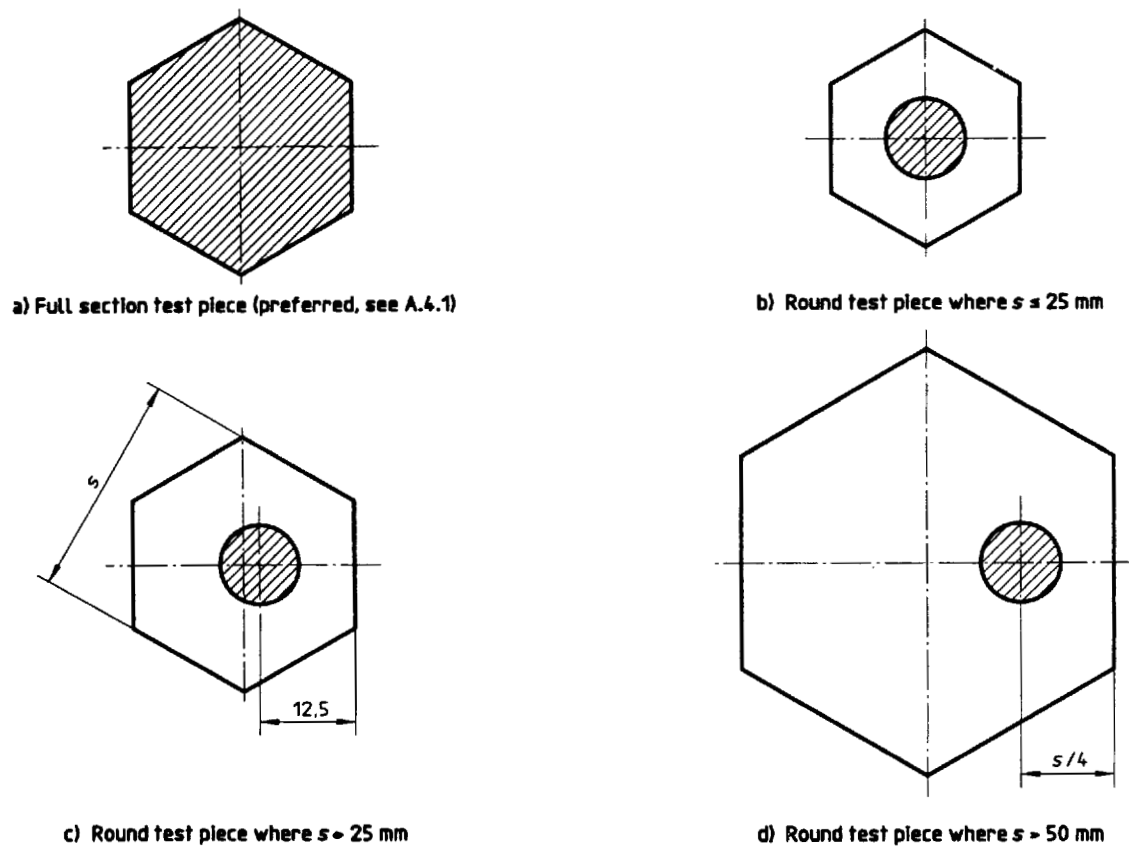

Figure A.6 — Hexagonal bar — Location of test pieces for tensile testing (see A.4.1)

Dimensions in millimetres

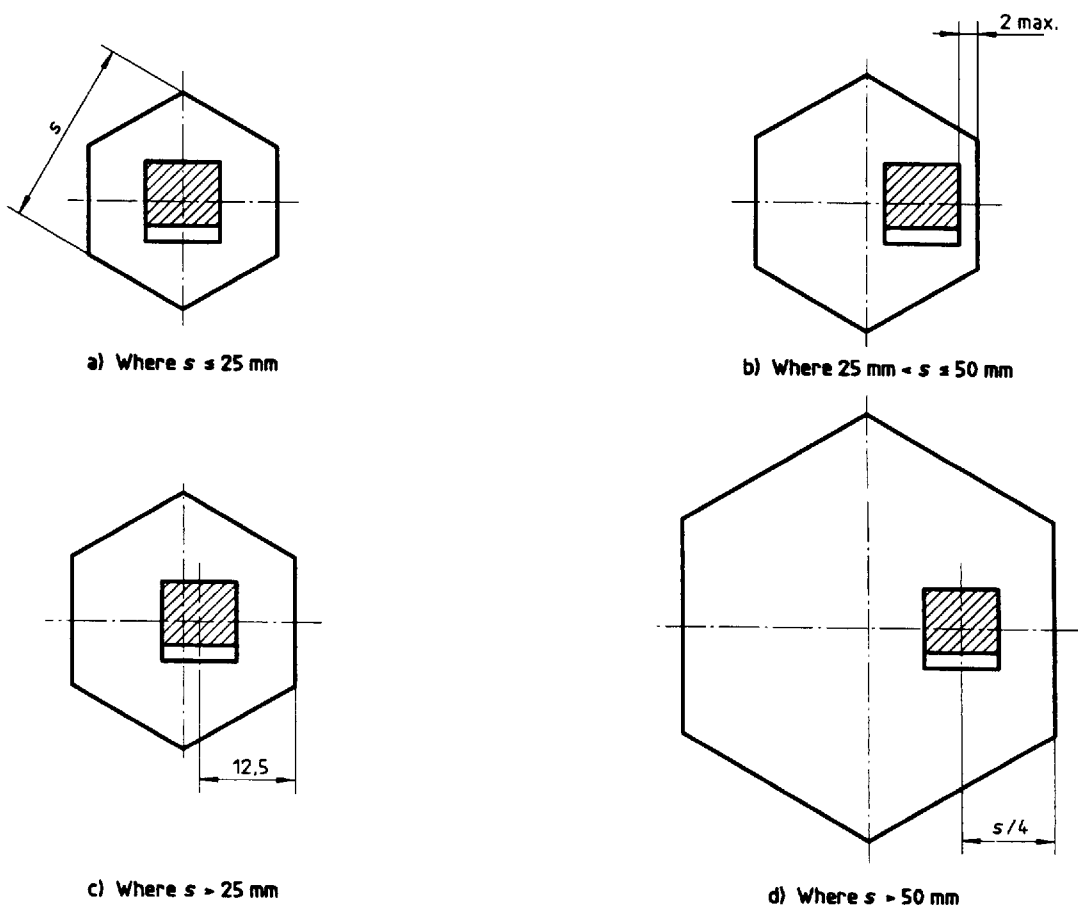
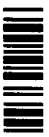

Figure A.7 — Hexagonal bar — Location of test pieces for impact testing (see A.4.2)



* S *

EN ISO 377 : 1997

Dimensions in millimetres

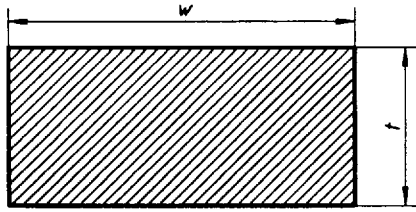

a) Full section test piece (wherever possible) see A.5.1

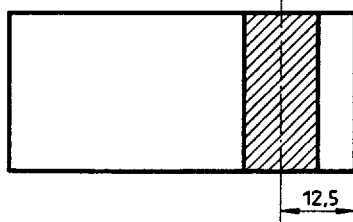

b) Rectangular test piece where $w \leq 50$ mm

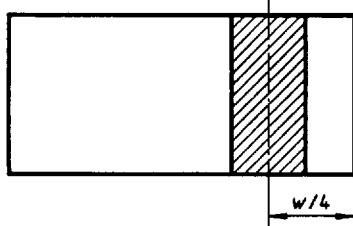

c) Rectangular test piece where $w > 50$ mm

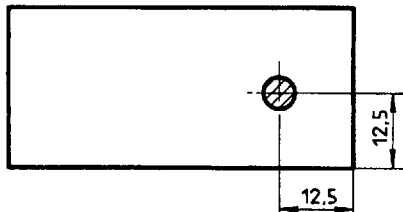

d) Round test piece where $w \leq 50$ mm and $t \leq 50$ mm

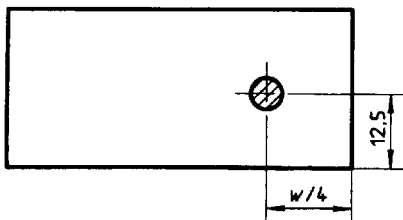

e) Round test piece where $w > 50$ mm and $t \leq 50$ mm

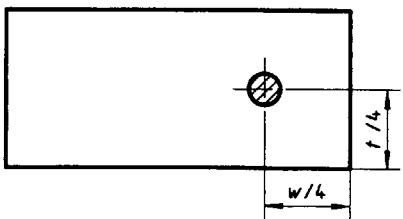

f) Round test piece where $w \leq 50$ mm and $t > 50$ mm

Figure A.8 — Rectangular bar — Location of test pieces for tensile testing (see A.5.1)

Dimensions in millimetres

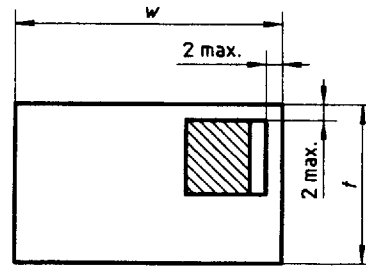

a) Where $12 \text{ mm} \leq w \leq 50 \text{ mm}$ and $t \leq 50 \text{ mm}$

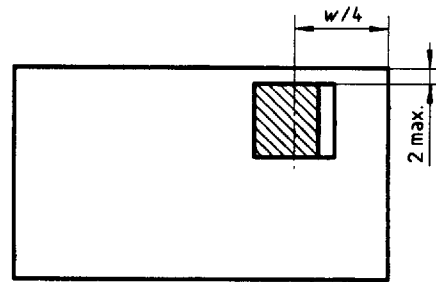

b) Where $w > 50 \text{ mm}$ and $t \leq 50 \text{ mm}$

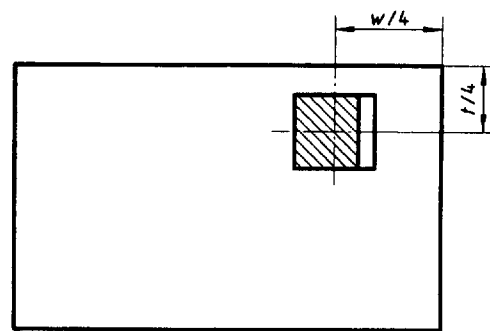

c) Where $w > 50 \text{ mm}$ and $t > 50 \text{ mm}$

Figure A.9 — Rectangular bar — Location of test pieces for impact testing (see A.5.2)

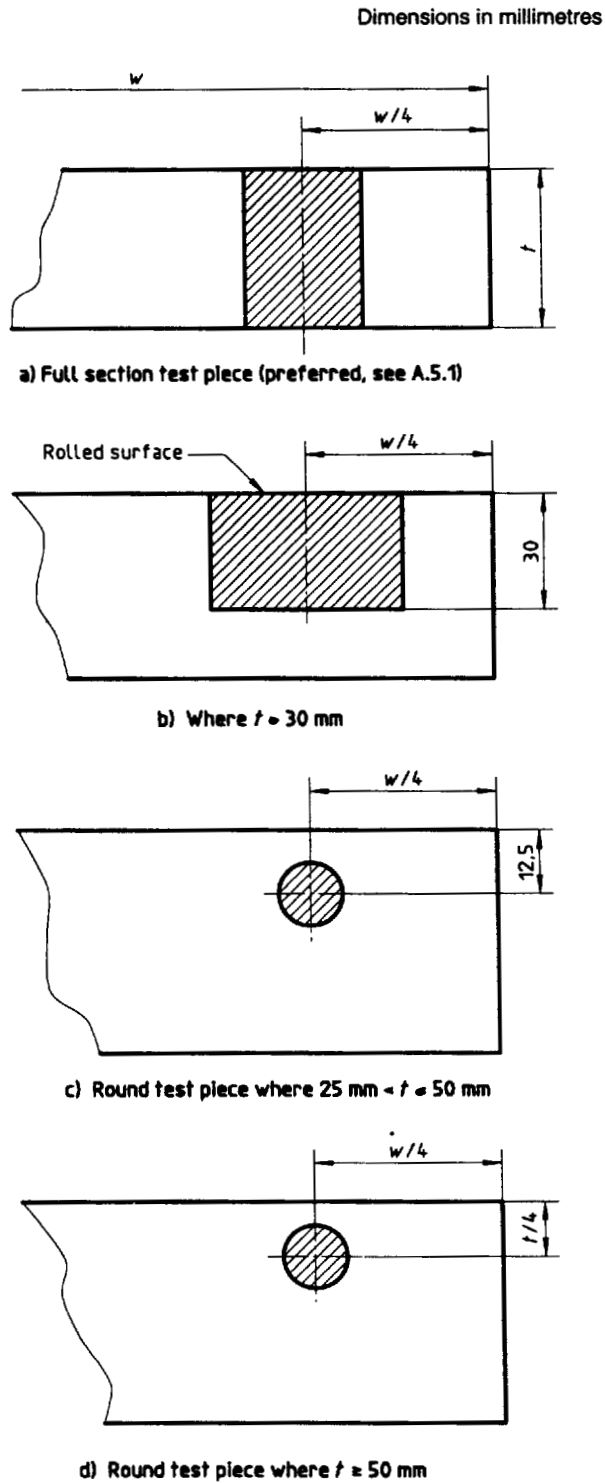

Figure A.10 — Flat products — Location of test pieces for tensile testing (see A.6.1)

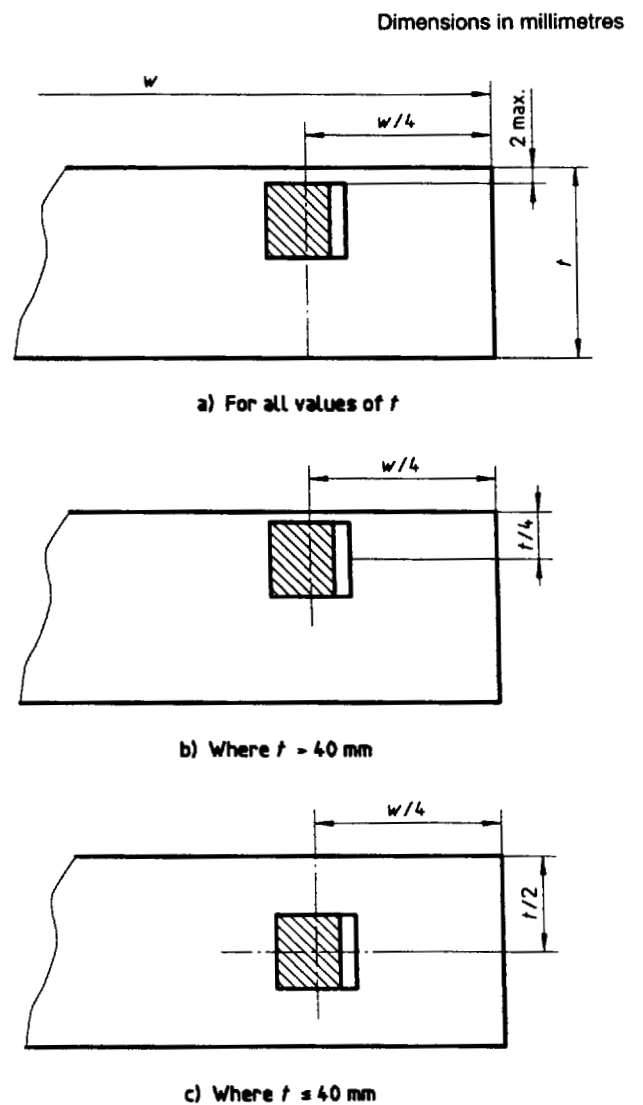
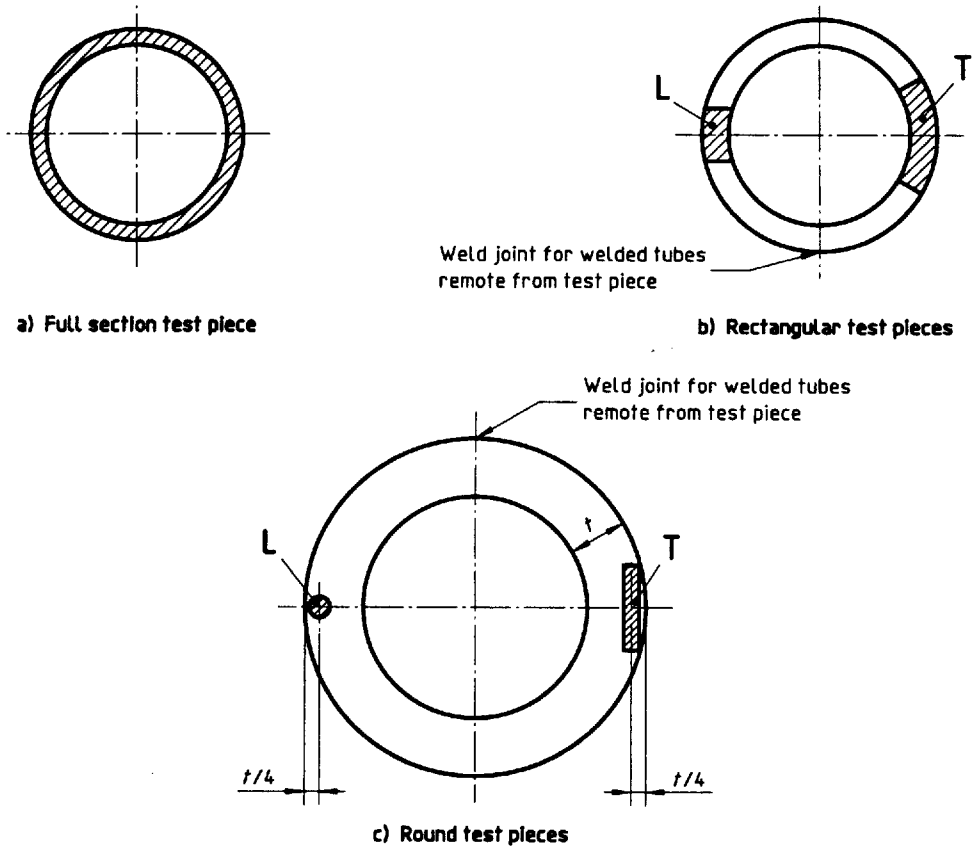

Figure A.11 — Flat products — Location of test pieces for impact testing (see A.6.2)

* 5 *

EN ISO 377 : 1997



L = Longitudinal test piece
T = Transverse test piece

Figure A.12 — Tubular products — Location of test pieces for tensile testing of tubes and circular hollow sections (see A.7.1.1)

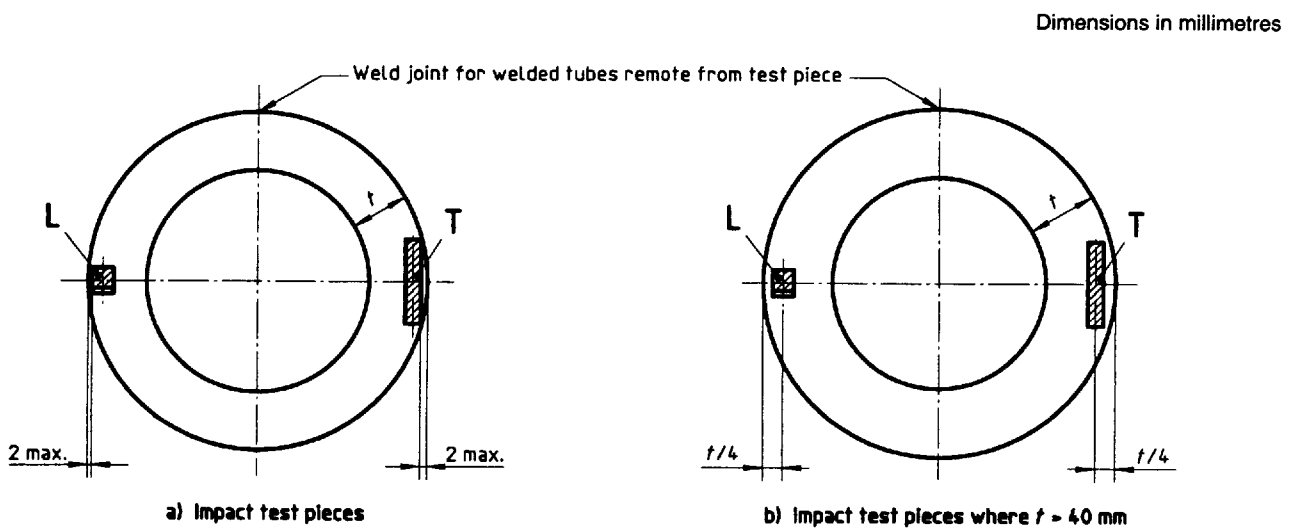

L = Longitudinal test piece
T = Transverse test piece

Figure A.13 — Tubular products — Location of test pieces for impact testing of tubes and circular hollow sections (see A.7.1.2)

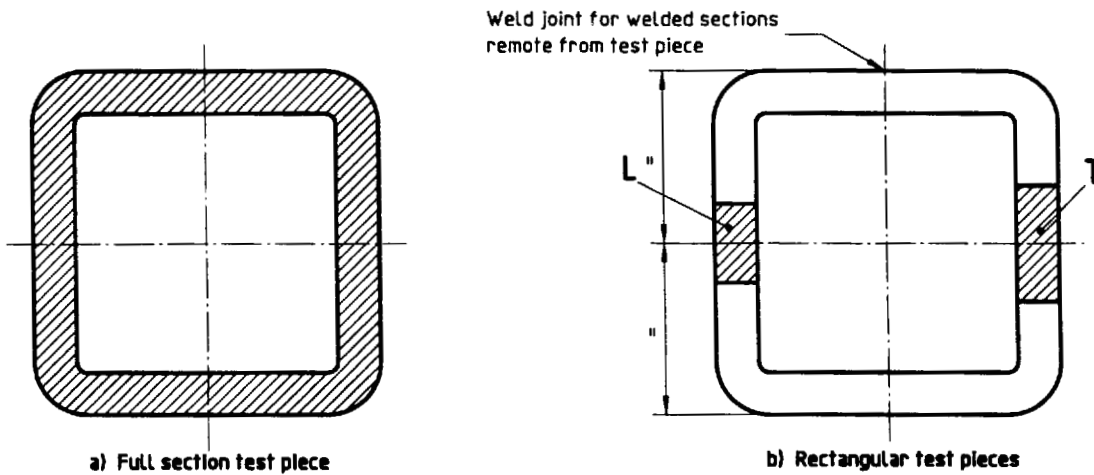

L = Longitudinal test piece
T = Transverse test piece

Figure A.14 — Tubular products — Location of test pieces for tensile testing of hollow sections (see A.7.2.1)

Dimensions in millimetres

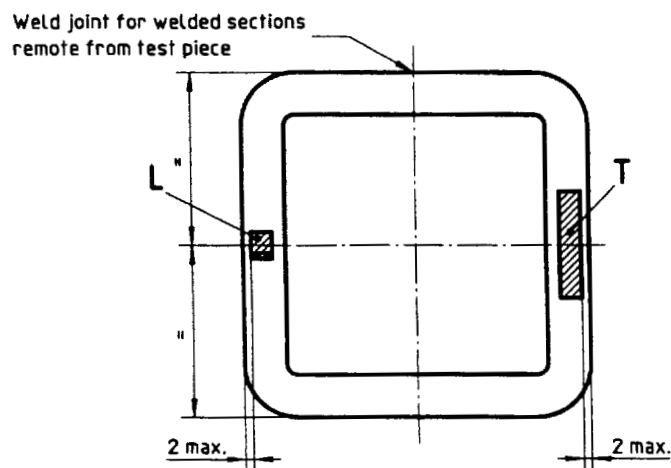

L = Longitudinal test piece
T = Transverse test piece

Figure A.15 — Tubular products — Location of test pieces for impact testing of hollow section (see A.7.2.2)

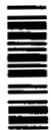

S

EN ISO 377 : 1997**Annex ZA (normative)****Normative references to international publications
with their relevant European publications**

This European Standard incorporates by dated or undated reference, provisions from other publications. These normative references are cited at the appropriate places in the text and the publications are listed hereafter. For dated references, subsequent amendments to or revisions of any of these publications apply to this European Standard only when incorporated in it by amendment or revision. For undated references the latest edition of the publication referred to applies.

<u>Publication</u>	<u>Year</u>	<u>Title</u>	<u>EN</u>	<u>Year</u>
ISO 3785	1976	Steel - Designation of test piece axes	EN ISO 3785	1995

BSI — British Standards Institution

BSI is the independent national body responsible for preparing British Standards. It presents the UK view on standards in Europe and at the international level. It is incorporated by Royal Charter.

Contract requirements

A British Standard does not purport to include all the necessary provisions of a contract. Users of British Standards are responsible for their correct application.

Revisions

British Standards are updated by amendment, or revision. Users of British Standards should make sure that they possess the latest amendments or editions.

It is the constant aim of BSI to improve the quality of our products and services. We would be grateful if anyone finding an inaccuracy or ambiguity while using this British Standard would inform the Secretary of the responsible technical committee, the identity of which can be found on the inside front cover. Tel: 0181 996 9000; Fax: 0181 996 7400.

BSI offers members an individual updating service called PLUS which ensures that subscribers automatically receive the latest editions of standards.

Buying standards

Orders for all BSI, international and foreign standards publications should be addressed to Customer Services, Sales Department at Chiswick: Tel: 0181 996 7000; Fax: 0181 996 7001.

In response to orders for international standards, it is BSI policy to supply the BSI implementation of those that have been published as British Standards, unless otherwise requested.

Information on standards

BSI provides a wide range of information on national, European and international standards through its Library, the Standardline Database, the BSI Information Technology Service (BITS) and its Technical Help to Exporters Service. Contact the Information Department at Chiswick: Tel: 0181 996 7111; Fax: 0181 996 7048.

Subscribing members of BSI are kept up to date with standards developments and receive substantial discounts on the purchase price of standards. For details of these and other benefits contact Customer Services, Membership at Chiswick: Tel: 0181 996 7002; Fax: 0181 996 7001.

Copyright

Copyright subsists in all BSI publications. BSI also holds the copyright, in the UK, of the publications of the international standardization bodies. Except as permitted under the Copyright, Designs and Patents Act 1988 no extract may be reproduced, stored in a retrieval system or transmitted in any form or by any means – electronic, photocopying, recording or otherwise – without prior written permission from BSI.

This does not preclude the free use, in the course of implementing the standard, of necessary details such as symbols, and size, type or grade designations. If these details are to be used for any other purpose than implementation then the prior written permission of BSI must be obtained.

If permission is granted, the terms may include royalty payments or a licensing agreement. Details and advice can be obtained from the Copyright Manager, BSI, 389 Chiswick High Road, London W4 4AL.

BSI
389 Chiswick High Road
London
W4 4AL